

REVISIONS				
REV.	ER	DESCRIPTION	BY	DATE

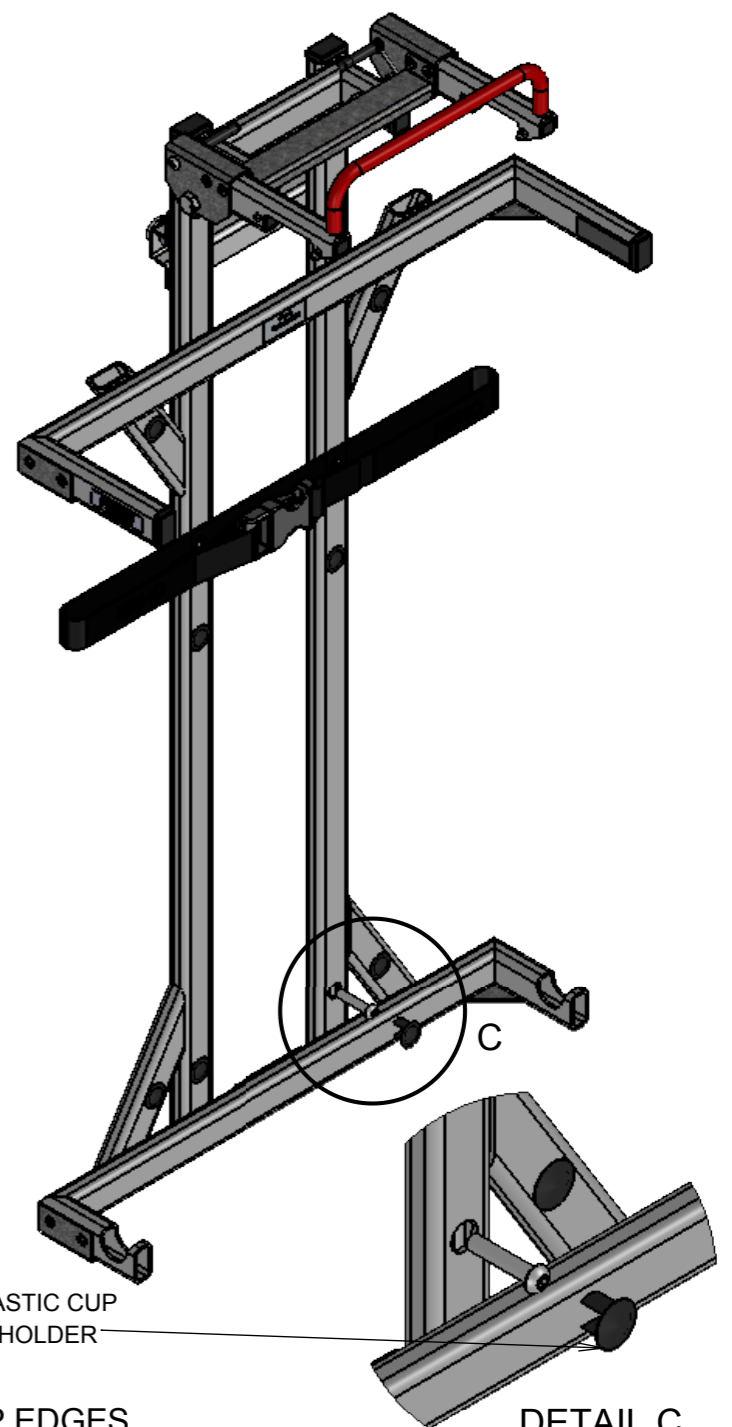
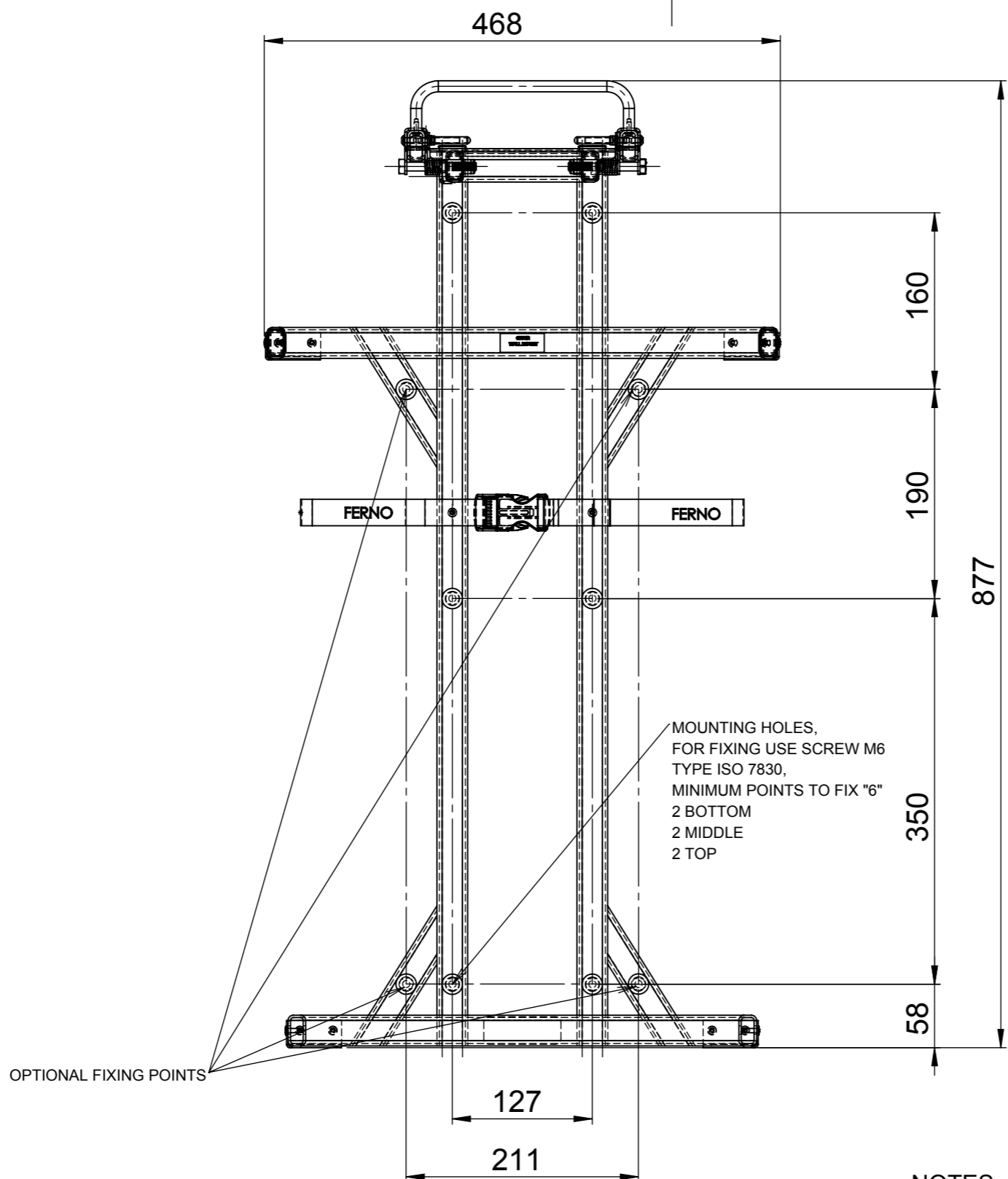
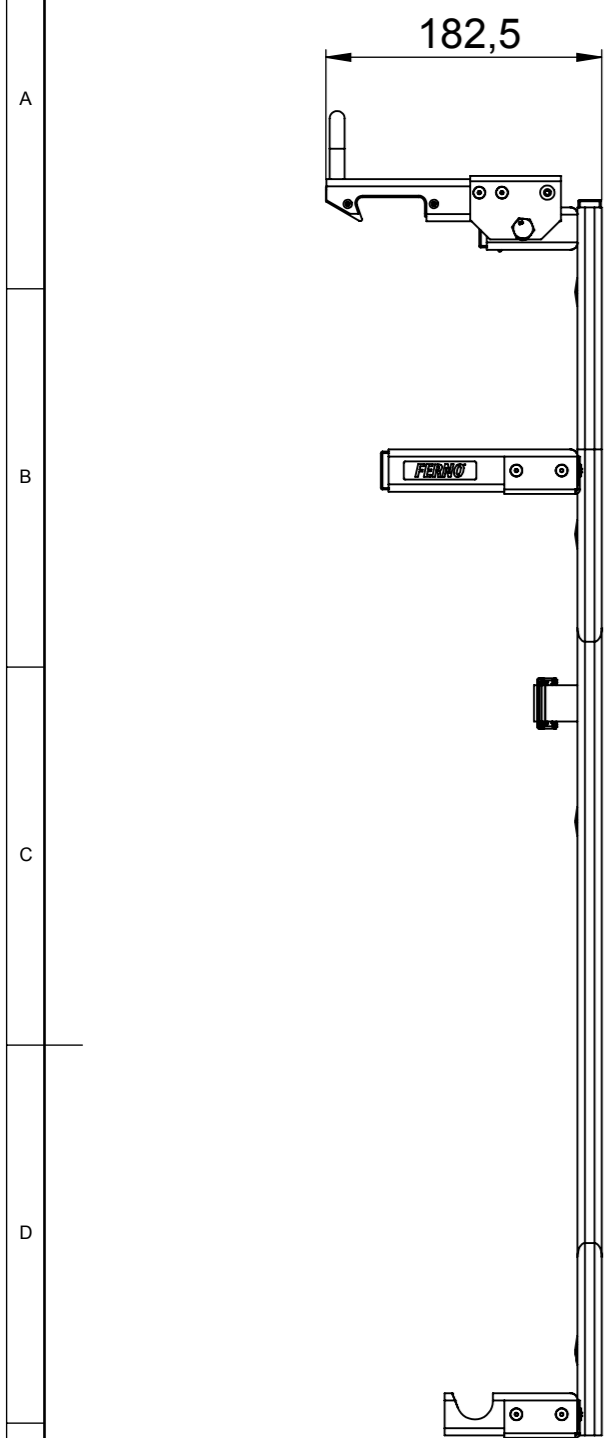

APPLY AESTHETIC PLASTIC CUP AFTER INSTALLATION HOLDER

DETAIL C  
SCALE 2 : 5

- NOTES:
- DEBURR ALL SHARP EDGES
  - APPROX. WEIGHT 2,4 KG

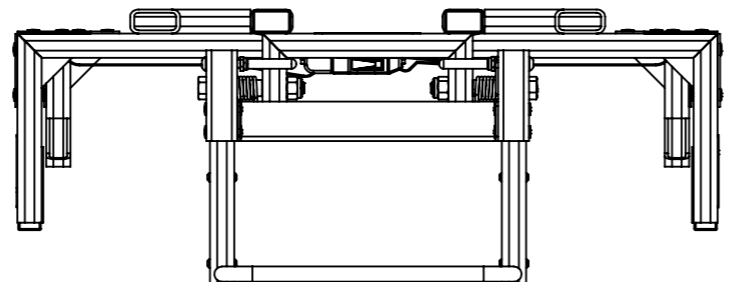

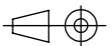
GENERAL TOLERANCES COMPLY WITH <b>STN ISO 2768-mK</b>		THIS DRAWING IS THE PROPERTY OF FERNO SLOVAKIA S.R.O., IT IS NOT TO BE COPIED OR DUPLICATED IN ANY MANNER, AND SHALL NOT BE SUBMITTED TO OUTSIDE PARTIES FOR EXAMINATION WITHOUT OUR KNOWLEDGE AND CONSENT. IT SHALL BE USED AS A MEANS OF REFERENCE TO WORK FURNISHED BY THIS COMPANY ONLY.		
DRAWN BY <b>A.TURIAK</b>	DATE <b>08.01.2018</b>	 <b>FERNO-SLOVAKIA, s.r.o.</b> Bosaca 893, 913 07 Slovak Republic		
MATERIAL NONE	NONE	FIRST ANGLE PROJECTION 	SCALE: <b>1:10</b>	SHEET: <b>1 OF 2</b>
FINISH NONE	NONE	DESCRIPTION <b>CH.W. MOUNT - INSTALLATION INSTR.</b>		
REFERENCE NONE	SIZE <b>A3</b>	PART NO. <b>50-8190-001</b>	REVISION <b>A</b>	

ENTERPRISE INFORMATION	
PART/ASSEMBLY FILE NAME <b>61-4190-001</b>	DRAWING FILE NAME <b>50-8190-001</b>

