

WHELEN[®]

ENGINEERING COMPANY INC.

51 Winthrop Road
Chester, Connecticut 06412-0684
Phone: (860) 526-9504
Internet: www.whelen.com
Sales e-mail: autosale@whelen.com
Customer Service e-mail: custserv@whelen.com

Installation Guide:
Arges™ Remote Spotlight
Universal Flat Mount

Warnings to Installers

Whelen's emergency vehicle warning devices must be properly mounted and wired in order to be effective and safe. Read and follow all of Whelen's written instructions when installing or using this device. Emergency vehicles are often operated under high speed stressful conditions which must be accounted for when installing all emergency warning devices. Controls should be placed within convenient reach of the operator so that they can operate the system without taking their eyes off the roadway. Emergency warning devices can require high electrical voltages and/or currents. Properly protect and use caution around live electrical connections. Grounding or shorting of electrical connections can cause high current arcing, which can cause personal injury and/or vehicle damage, including fire. Many electronic devices used in emergency vehicles can create or be affected by electromagnetic interference. Therefore, after installation of any electronic device it is necessary to test all electronic equipment simultaneously to insure that they operate free of interference from other components within the vehicle. Never power emergency warning equipment from the same circuit or share the same grounding circuit with radio communication equipment. All devices should be mounted in accordance with the manufacturer's instructions and securely fastened to vehicle elements of sufficient strength to withstand the forces applied to the device. Driver and/or passenger air bags (SRS) will affect the way equipment should be mounted. This device should be mounted by permanent installation and within the zones specified by the vehicle manufacturer, if any. Any device mounted in the deployment area of an air bag will damage or reduce the effectiveness of the air bag and may damage or dislodge the device. Installer must be sure that this device, its mounting hardware and electrical supply wiring does not interfere with the air bag or the SRS wiring or sensors. Mounting the unit inside the vehicle by a method other than permanent installation is not recommended as unit may become dislodged during swerving; sudden braking or collision. Failure to follow instructions can result in personal injury. Whelen assumes no liability for any loss resulting from the use of this warning device. **PROPER INSTALLATION COMBINED WITH OPERATOR TRAINING IN THE PROPER USE OF EMERGENCY WARNING DEVICES IS ESSENTIAL TO INSURE THE SAFETY OF EMERGENCY PERSONNEL AND THE PUBLIC.**

Warnings to Users

Whelen's emergency vehicle warning devices are intended to alert other operators and pedestrians to the presence and operation of emergency vehicles and personnel. However, the use of this or any other Whelen emergency warning device does not guarantee that you will have the right-of-way or that other drivers and pedestrians will properly heed an emergency warning signal. Never assume you have the right-of-way. It is your responsibility to proceed safely before entering an intersection, driving against traffic, responding at a high rate of speed, or walking on or around traffic lanes. Emergency vehicle warning devices should be tested on a daily basis to ensure that they operate properly. When in actual use, the operator must ensure that both visual and audible warnings are not blocked by vehicle components (i.e.: open trunks or compartment doors), people, vehicles, or other obstructions. It is the user's responsibility to understand and obey all laws regarding emergency warning devices. The user should be familiar with all applicable laws and regulations prior to the use of any emergency vehicle warning device. Whelen's audible warning devices are designed to project sound in a forward direction away from the vehicle occupants. However, because sustained periodic exposure to loud sounds can cause hearing loss, all audible warning devices should be installed and operated in accordance with the standards established by the National Fire Protection Association.

Safety First

This document provides all the necessary information to allow your Whelen product to be properly and safely installed. Before beginning the installation and/or operation of your new product, the installation technician and operator must read this manual completely. Important information is contained herein that could prevent serious injury or damage.

⚠ WARNING: This product can expose you to chemicals including Lead which is known to the State of California to cause cancer and birth defects or other reproductive harm. For more information go to www.P65Warnings.ca.gov.

- **Proper installation of this product requires the installer to have a good understanding of automotive electronics, systems and procedures.**
- **Whelen Engineering requires the use of waterproof butt splices and/or connectors if that connector could be exposed to moisture.**
- **Any holes, either created or utilized by this product, should be made both air- and watertight using a sealant recommended by your vehicle manufacturer.**
- **Failure to use specified installation parts and/or hardware will void the product warranty.**
- **If mounting this product requires drilling holes, the installer MUST be sure that no vehicle components or other vital parts could be damaged by the drilling process. Check both sides of the mounting surface before drilling begins. Also de-burr the holes and remove any metal shards or remnants. Install grommets into all wire passage holes.**
- **If this manual states that this product may be mounted with suction cups, magnets, tape or Velcro®, clean the mounting surface with a 50/50 mix of isopropyl alcohol and water and dry thoroughly.**
- **Do not install this product or route any wires in the deployment area of your air bag. Equipment mounted or located in the air bag deployment area will damage or reduce the effectiveness of the air bag, or become a projectile that could cause serious personal injury or death. Refer to your vehicle owner's manual for the air bag deployment area. The User/Installer assumes full responsibility to determine proper mounting location, based on providing ultimate safety to all passengers inside the vehicle.**
- **For this product to operate at optimum efficiency, a good electrical connection to chassis ground must be made. The recommended procedure requires the product ground wire to be connected directly to the NEGATIVE (-) battery post (this does not include products that use cigar power cords).**
- **If this product uses a remote device for activation or control, make sure that this device is located in an area that allows both the vehicle and the device to be operated safely in any driving condition.**
- **Do not attempt to activate or control this device in a hazardous driving situation.**
- **This product contains either strobe light(s), halogen light(s), high-intensity LEDs or a combination of these lights. Do not stare directly into these lights. Momentary blindness and/or eye damage could result.**
- **Use only soap and water to clean the outer lens. Use of other chemicals could result in premature lens cracking (crazing) and discoloration. Lenses in this condition have significantly reduced effectiveness and should be replaced immediately. Inspect and operate this product regularly to confirm its proper operation and mounting condition. Do not use a pressure washer to clean this product.**
- **It is recommended that these instructions be stored in a safe place and referred to when performing maintenance and/or reinstallation of this product.**
- **FAILURE TO FOLLOW THESE SAFETY PRECAUTIONS AND INSTRUCTIONS COULD RESULT IN DAMAGE TO THE PRODUCT OR VEHICLE AND/OR SERIOUS INJURY TO YOU AND YOUR PASSENGERS!**

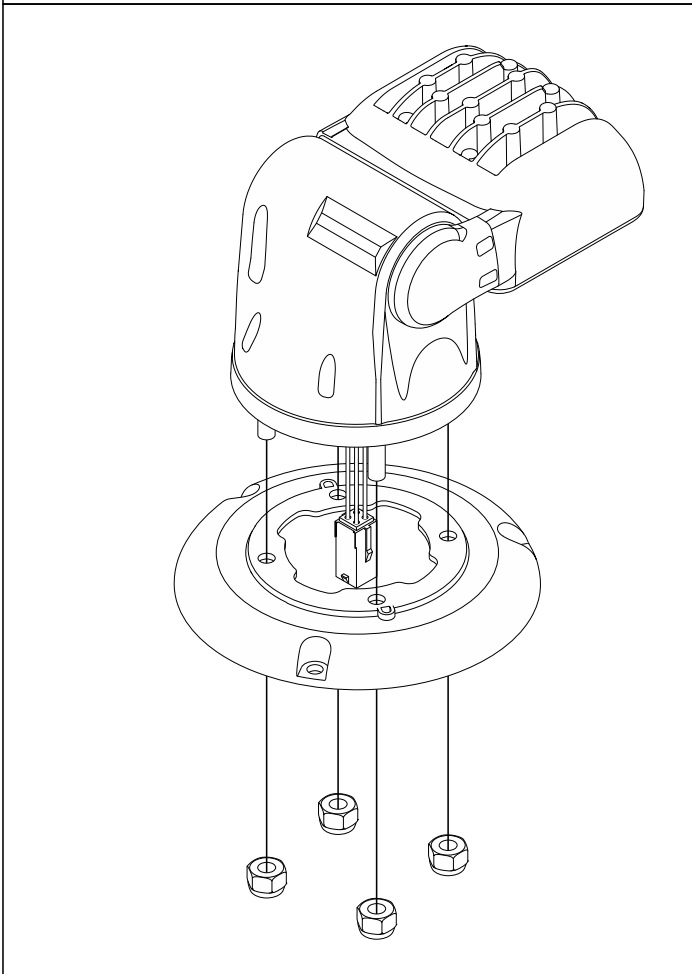
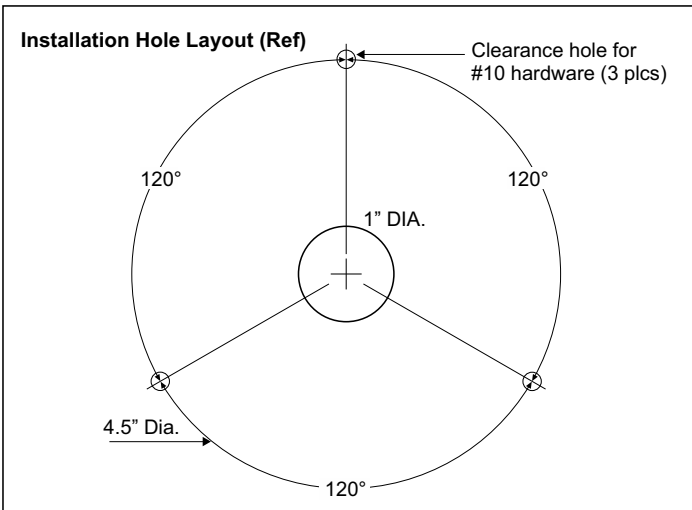

1. Using the hardware provided, mount the light assembly onto the base as shown.

Note:
Light shown in 'Home' position

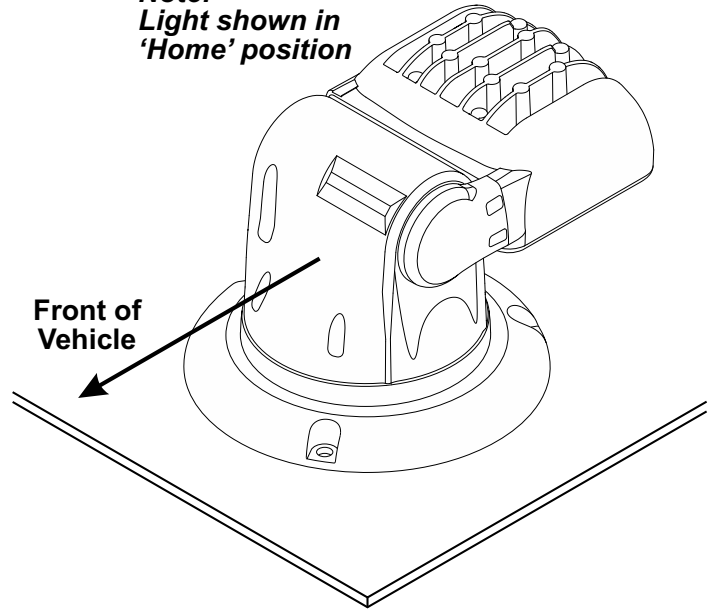

IMPORTANT! This product is designed to be mounted onto a flat, smooth surface. Do not install on either a curved, uneven or diamond plate-style surface!

2. Position the Light and Base onto the proposed mounting surface in its desired location. Using the base as a template, mark the locations for the three (3) mounting holes. Remove the assembly from the mounting surface.
3. Drill the mounting holes using a bit sized to create a clearance hole for #10 hardware.

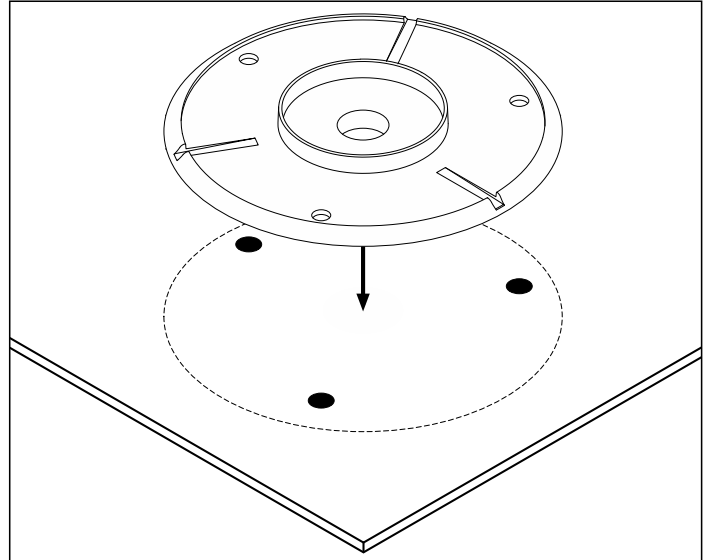

4. Locate the mounting gasket and place it onto the mounting surface so that all the holes are aligned. Using the gasket as a template, mark the area for the wire passage hole. Remove the gasket and create a 1" dia. hole in the are marked. De-burr all 4 holes before continuing.

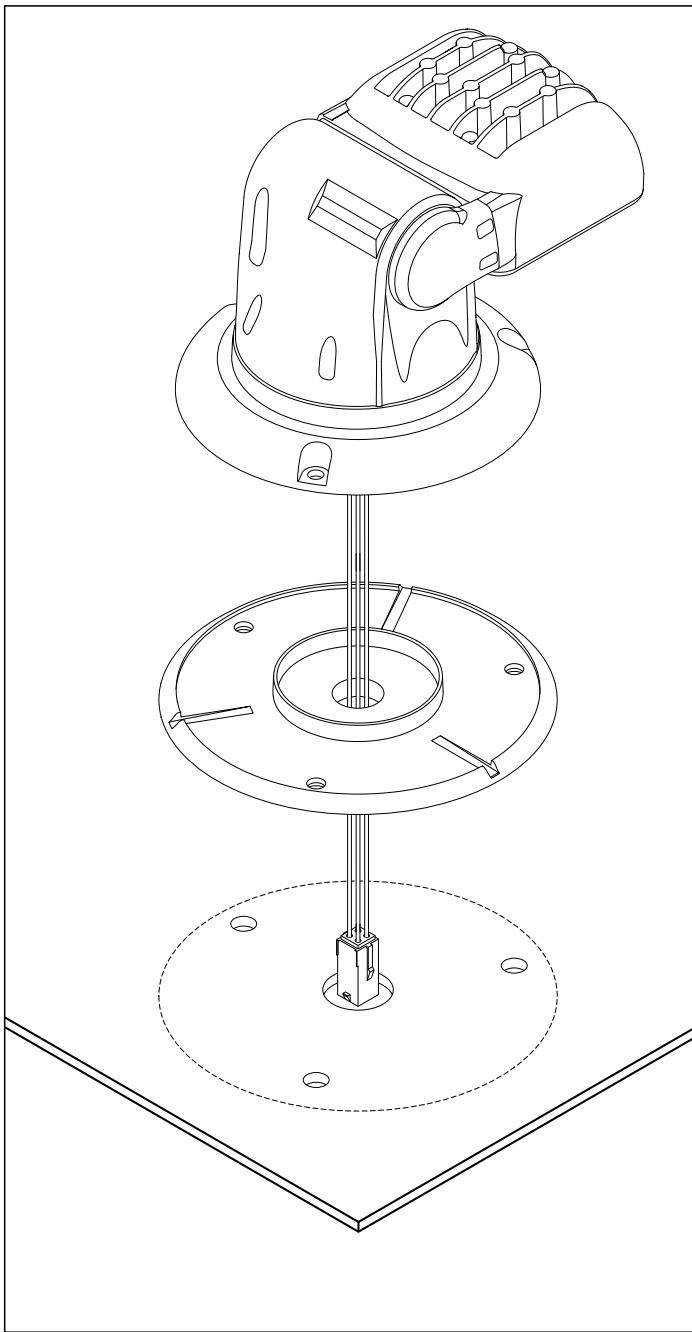

5. Return the mounting gasket to its proper position. Route the wire connector down through the wire passage hole. Place the light/base assembly onto the gasket, making sure the wires are not pinched .

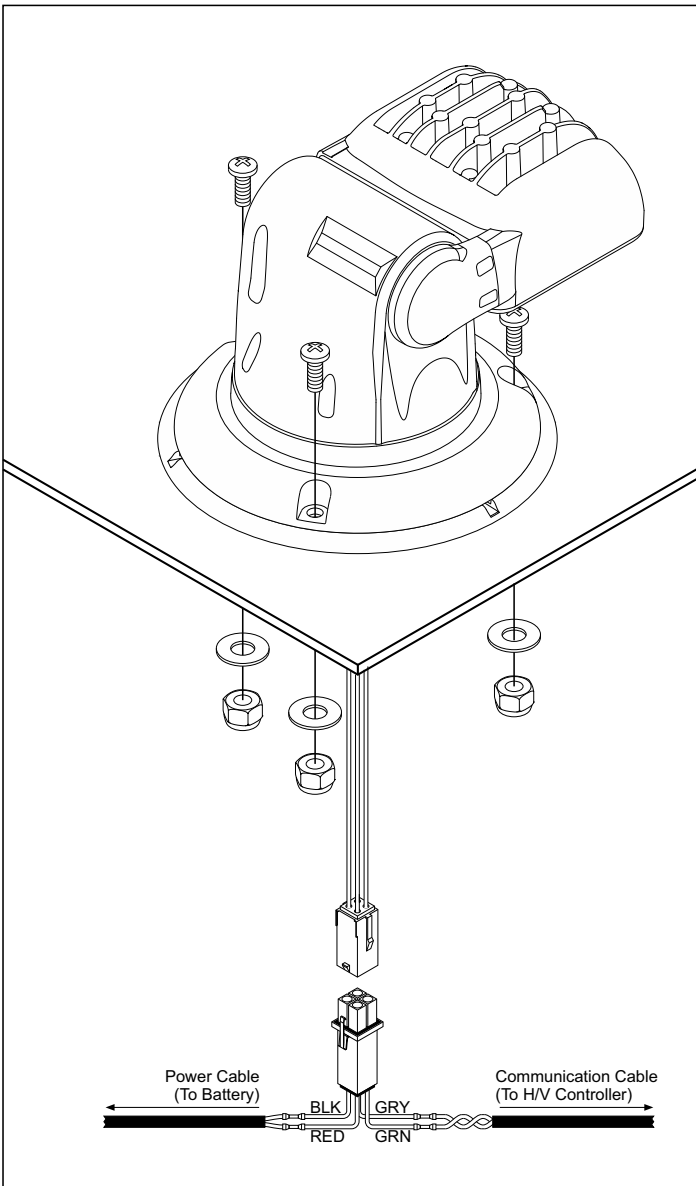

6. Using the hardware provided, secure the light/base assembly to the mounting surface as shown. Tighten firmly.
7. This completes the mounting of the Light Assembly. The following pages will address wiring, operation and configuration.

Wiring...

Important! When routing wires, existing factory wire paths should be followed whenever possible.

1. Locate the 4-position pigtail included with your spotlight. This connector will be plugged into the spotlight assembly after all wiring is completed.
2. Using appropriately sized wire, extend the Red and Black wires towards the vehicle battery. Install a 7.5 amp fuse block on the Red wire and connect to +12VDC. Connect the Black wire to chassis ground.
3. Extend the WHT/BLK wire to the vehicle dashboard illumination circuit.
4. Locate the twisted pair communication cable (included). Connect the Green and Grey wires from the light assembly to the communication cable. Route this cable to the spotlight control head's installed location.
5. Locate the 4-position Control Head Harness Plug. Connect the communication cable to the Green and Grey wires on the harness plug.
6. Using appropriately sized wire gage, extend the Red wire to an ignition-controlled circuit. Install a 1 amp fuse block on this wire and connect to +12VDC.
7. Using appropriately sized wire gage, extend the Black wire to chassis ground.
8. The 4-position pigtail can now be connected to the spotlight.

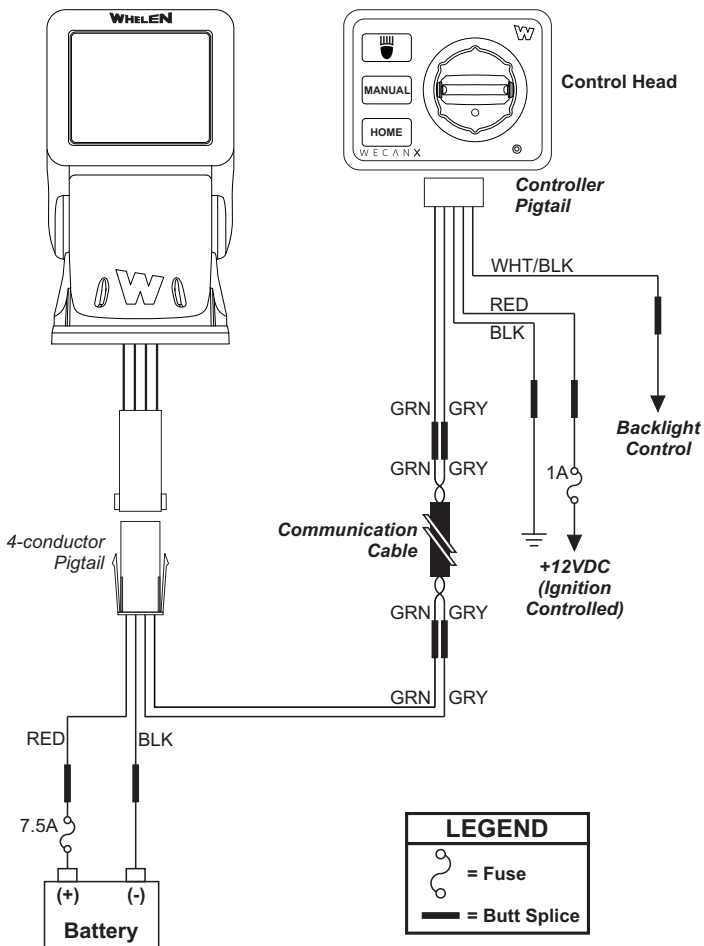

Operation...

Important! Proper operation of the Argos Remote Spotlight requires the controller to be mounted and immovable. It is beyond the scope of this manual to prescribe a specific mounting style, as that will be determined by the installer based on that specific vehicle. Regardless of the location or mounting style selected, it is important that the controller be positioned in a location that allows easy access and does not interfere with any existing equipment.

Note: Placing or installing any components that contain magnets within 3 inches of the Argos controller can temporarily disrupt proper operation.

The controller consists of the following:

- 3 Control Buttons.
- H/V (Horizontal/Vertical) control with Orientation Indicator.

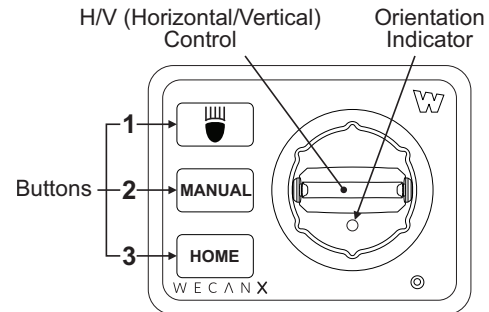

Control Buttons....

There are 3 control buttons. Their function is as follows:

Button 1 (Spotlight) - Turns the spotlight on and off. This button will turn Red to indicate when it is active.

Button 1 (ProFocus only) - With the lighthouse off, a single-tap turns the lighthouse on in **Spot** mode. A double-tap turns the lighthouse on in **Flood** mode.

With the lighthouse on, a single-tap turns the lighthouse off. A double tap will toggle the lighthouse between **Spot** and **Flood** mode.

Button 2 (Manual) - Allows the spotlight to be turned/aimed by hand.

Button 3 (Home) - The first tap turns the lighthouse off and returns the Argos to its 'Home' position. A second tap will position the Argos to match the orientation of the H/V control, but the lighthouse will remain off.

H/V Interface Control....

This is a dual-axis control that is used to aim the spotlight in the desired direction. It consists of a Horizontal and Vertical control, as well as an orientation indicator. This indicator represents the direction the lighthouse is facing in relation to the H/V control.

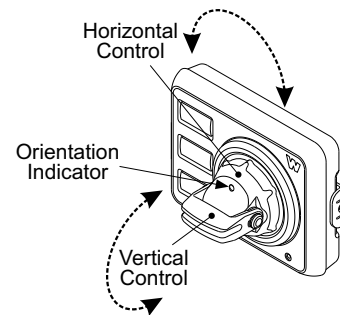

Horizontal control rotates the light assembly 360° along its horizontal axis. If this control is rotated in a given direction, the spotlight will rotate proportionately in the same direction.

Vertical control tilts the lighthouse 180° up and down along its vertical axis. If this control is tilted away from the orientation indicator, the spotlight will tilt upwards. If it is tilted towards the indicator, the spotlight will tilt downwards.

Keypad Identification Label...

Installation

1. Remove a key cover from the sprue.
2. Remove the label that best describes the function of the designated button from the label sheet.
3. Position the label onto the key so that it is centered and properly oriented.
4. Press the key cover onto the key until the retaining fingers lock into place. **NOTE! The key cover must be square to the control head during installation. Do not force the cover onto the key!**

Removal

To remove the key cover gently release the retaining fingers using a small, flat-blade screwdriver or similar tool. Be sure to follow the same removal angle as during installation.

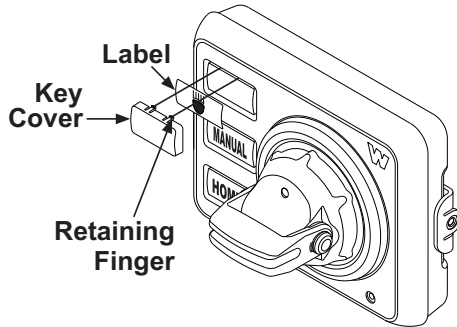

Calibration...

After installation is complete, the 'Home Position' for your remote spotlight must now be calibrated. The following procedure establishes the proper Home Position orientation for your specific installation.

NOTE: The calibration procedure is the same for both Driver-side and Passenger-side installations. The artwork shown is for reference only.

1. Disconnect the control head from power.
2. Press all three control head buttons simultaneously.
3. While holding all three buttons down, re-connect the control head to power. When power is applied, the control head will 'buzz' and all three buttons will turn Red to indicate the unit is in calibration mode. The buttons may now be released.
4. Manually adjust the position of the spotlight until it is:
 - a) fully upright
 - b) facing the rear of the vehicle

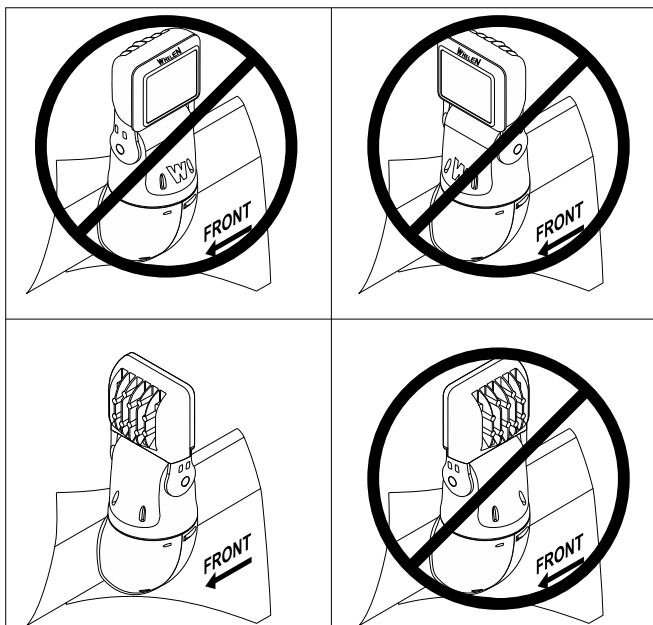

5. When the spotlight in this position, the control head must now be oriented to match the light. Position the H/V interface control so that:
 - a) the Vertical Control is fully upright
 - b) the Orientation Indicator is facing the rear of the vehicle.

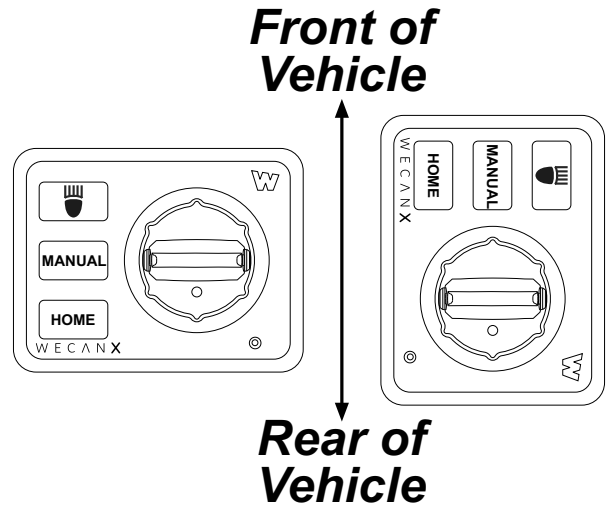

6. Press all three control head buttons simultaneously. The control head will 'buzz' and the buttons will return to their normal Blue color to indicate the unit is no longer in calibration mode. The buttons may now be released.
7. Operate the Horizontal and Vertical controls to familiarize yourself with control operation.
8. Now press Button #3. The light should move to the home position as shown below. If the light fails to move to the home position, repeat the procedure.

